

2025

UPFITTING CATALOG



Mercedes-Benz

VAN



— EST. 1975 —

INDUSTRIAL

TRUCK & VAN EQUIPMENT

800-833-0800 | IndustrialTruckandVan.com

PRIME DESIGN

A Clarience Technologies Company

ADRIAN

weather guard

THE ORIGINAL
TOMMY GATE

EST. 1942

LEGEND

TOPPER
MANUFACTURING
BUILT TO LAST

LEER

Holman
Driving What's Right

Van Installation Services



When it comes to work vans – If we sell, we install it



- At all our branches we employ factory trained technicians to insure your UpFit is correct and trouble free.
- We can install a pre-designed package or create a custom designed solution for unique business needs.
- Family owned and operated for over 50 years



Having the wrong Upfit can cost your business thousands per year



✦ **Van Partition / Bulkheads**
Safety, Security, Climate Control & Noise Reduction



✦ **Shelves, Cabinets & Tank Holders - Quick Tool Access, Organized Workflow & Inventory Management**



🔒 **Exterior Locks**
Protection for Tools & Equipment & Potential Insurance Benefits



✦ **Ladder Racks**
Maximized Cargo Space, Improved Safety and Security & Injury Reduction

At Industrial Truck and Van, we can make it happen.

💡 **Lighting (Interior & Exterior)**



✦ **Flooring & Liners**



👤 **Van Heaters**



💡 **Power Inverters**



🚚 **Lift Gates & Ramps**



NEW

WHY SETTLE FOR SHELVING THAT WASTES THE SPACE YOU PAID TO USE?

CARGO VANS ARE BIGGER THAN EVER BEFORE. TALLER, LONGER, AND PACKED WITH POTENTIAL.



LONGEST, TALLEST, DEEPEST SHELVES IN THE INDUSTRY

- LENGTHS UP TO 144"
- HEIGHTS UP TO 68"
- DEPTHS UP TO 16"



MIX-N-MATCH FLEXIBILITY

- 3 END PANEL HEIGHTS
- 9 SHELF LENGTHS
- 4 SHELF DEPTHS
- 2 ULTRA LONG SHELF CENTER SUPPORTS



IMPROVED ACCESSORIES

MAXIMIZE SHELF SPACE WITH THESE OPTIONS:

- 6 DRAWER UNITS
- 9 DOOR KITS
- 6 BINS
- 9 DIVIDERS



THIRD PARTY CRASH TESTED

INDUSTRY LEADING: UP TO 17 MOUNTING POINTS VS 7 MOUNTING POINTS



IMPROVED STRENGTH

50 LBS PER FOOT (AVG.) IS A 43% INCREASE IN STRENGTH VS 35 LBS PER FOOT (AVG.)



LET THERE BE LIGHT

CANTILEVERED DESIGN ALLOWS FOR MORE LIGHT TO SEE YOUR TOOLS AND CONSUMABLES BETTER

CONFIGURE YOUR WORK VAN WITH NEXT-GEN SHELVING

Eliminate dead space in your van's cargo area with Adrian Steel's Next Generation Shelving.

Compatible with our Next-Gen Accessories, our newest shelving line provides durable, customizable storage solutions that make every inch count in your work vehicle. Next-Gen Shelving comes in multiple end-panel heights, shelf depths, and lengths from 24" to 144".

Adrian NextGen Trade Packages / Mercedes Sprinter 144" WB - Low Roof

Base Shelving Package, Sprinter Low Roof 144" - BASE-SP-SR144

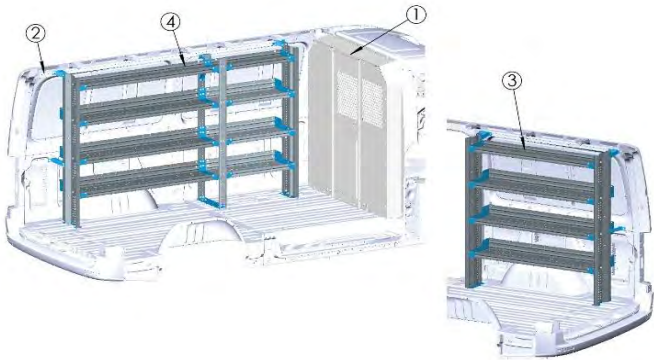

Bin Shelving Package, Sprinter Low Roof 144" - BIN-SP-SR144

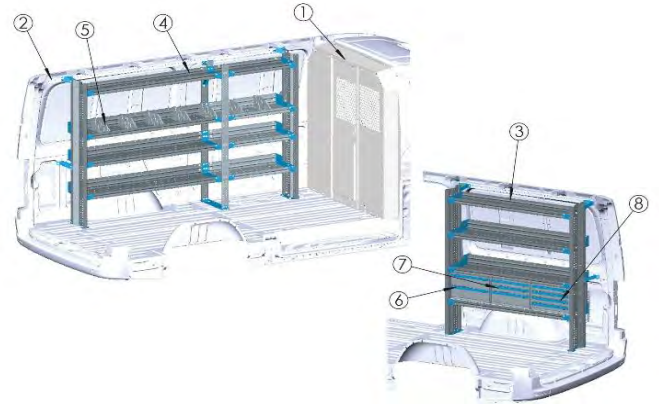

General Service Package, Mercedes Sprinter Standard Roof 144", GEN-SPSR144B

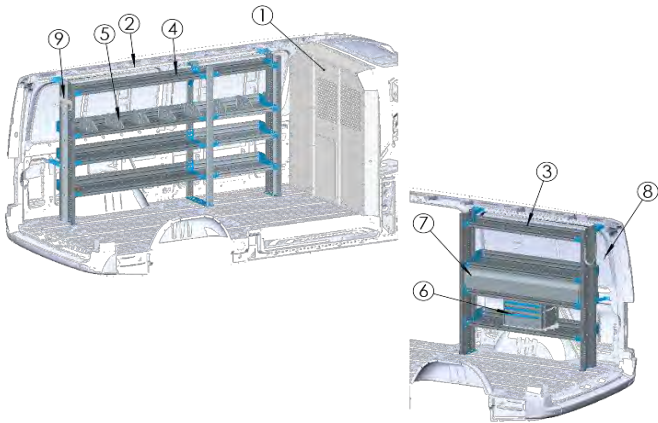

HVAC Essentials Package, Mercedes Sprinter Standard Roof 144", HVAC-SPSR144B

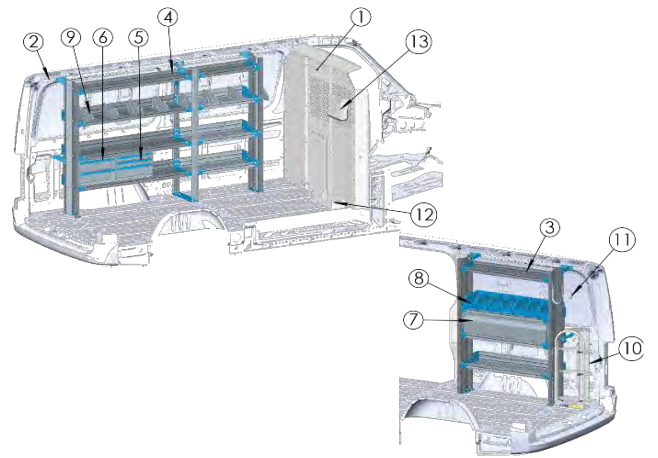

Electrical Essentials Package, Mercedes Sprinter Standard Roof 144", ELE-SPSR144B

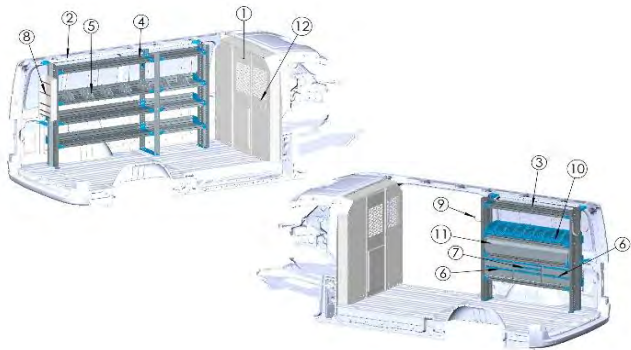

Plumbing Essentials Package, Mercedes Sprinter Standard Roof 144", PLUM-SPSR144B

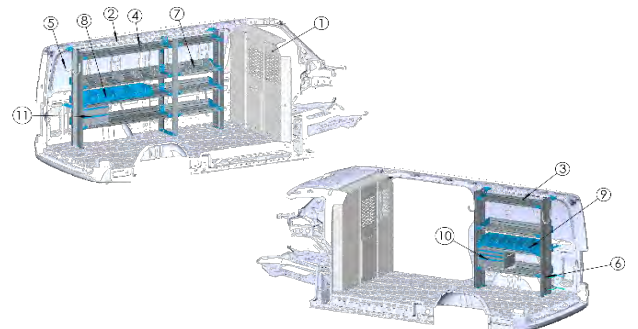

Adrian NextGen Trade Packages / Mercedes Sprinter 144" WB - Low Roof

Driver Side - Cabinet



Part Number:

AS-2T1484SPSA

Description:

4-Shelf Unit, Tank Rack & Cabinet Use, 14x84 (R54/F30)

Single Shelf Add-On Parts

AECK2T14A1

14" End Cap Kit, Single

ASFK2T1454G1

Shelf, 14 x 54

ASFK2T1430G1

Shelf, 14 x 30

ACSK14A1

14" Center Support Kit, Single Shelf

Driver Side - Long



Part Number:

AS-2T1490SPSA

Description:

4-Shelf Unit, 14x90 (R60/F30)

Single Shelf Add-On Parts

AECK2T14A1

14" End Cap Kit, Single

ASFK2T1460G1

Shelf, 14 x 60

ASFK2T1430G1

Shelf, 14 x 30

ACSK14A1

14" Center Support Kit, Single Shelf

Driver Side - Tank Rack



Part Number:

AS-2T1484SPSA

Description:

4-Shelf Unit, Tank Rack & Cabinet Use, 14x84 (R54/F30)

Single Shelf Add-On Parts

AECK2T14A1

14" End Cap Kit, Single

ASFK2T1454G1

Shelf, 14 x 54

ASFK2T1430G1

Shelf, 14 x 30

ACSK14A1

14" Center Support Kit, Single Shelf

Passenger Side - Long



Part Number:

AS-2T1454SPSA

Description:

4-Shelf Unit, 14x54

Single Shelf Add-On Parts

AECK2T14A1

14" End Cap Kit, Single

ASFK2T1454G1

Shelf, 14 x 54

Passenger Side - Short



Part Number:

AS-2T1442SPSA

Description:

4-Shelf Unit, Tank Rack Use, 14x42

Single Shelf Add-On Parts

AECK2T14A1

14" End Cap Kit, Single

ASFK2T1442G1

Shelf, 14 x 42

Rail Kits



Part Number:

ARKSP144

Description:

Mounting Rail Kit, Driver & Passenger Side

ARKSP144DS

Mounting Rail Kit, Driver Side

ARKSP144PS

Mounting Rail Kit, Passenger Side

All listed shelving units are 14" deep / 16" Deep shelves also available

"Short" units allow room at the rear of the vehicle to install accessories like tank racks.

"Long" units fill the maximum available length of the driver or passenger side to eliminate dead space.

Adrian NextGen Trade Packages / Mercedes Sprinter 144" WB - High Roof

Base Shelving Package, Sprinter High Roof 144 - BASE-SP-HR144

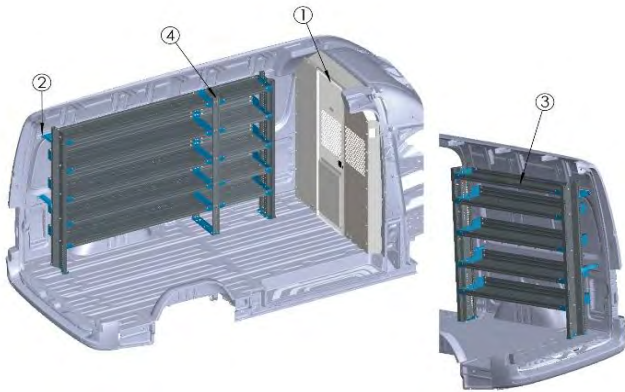

Bin Shelving Package, Sprinter High Roof 144 - BIN-SP-HR144

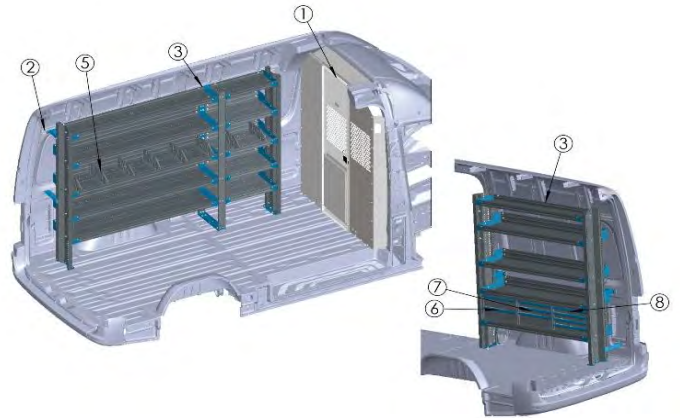

General Service Package, Mercedes Sprinter High Roof 144", GEN-SPHR144B

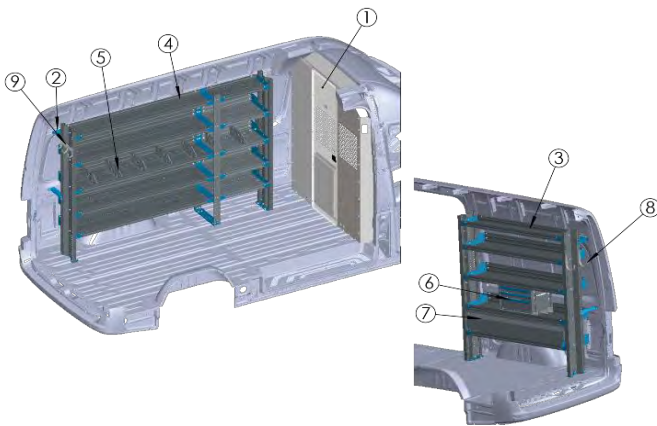

HVAC Essentials Package, Mercedes Sprinter High Roof 144", HVAC-SPHR144B

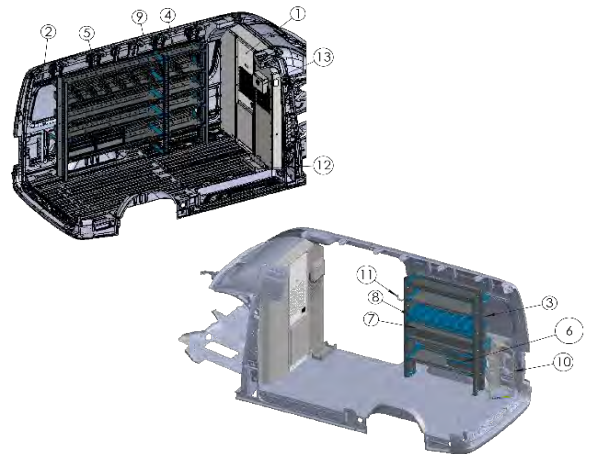

Electrical Essentials Package, Mercedes Sprinter High Roof 144", ELE-SPHR144B

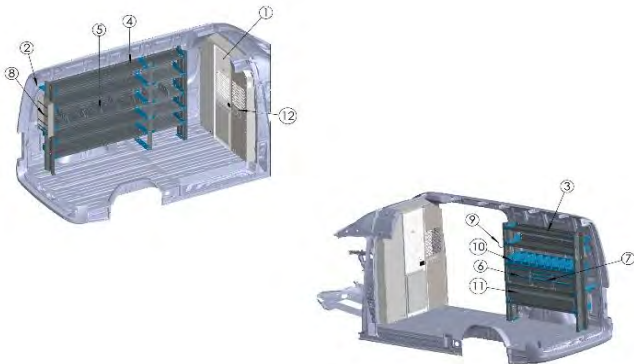

Plumbing Essentials Package, Mercedes Sprinter High Roof 144", PLUM-SPHR144B

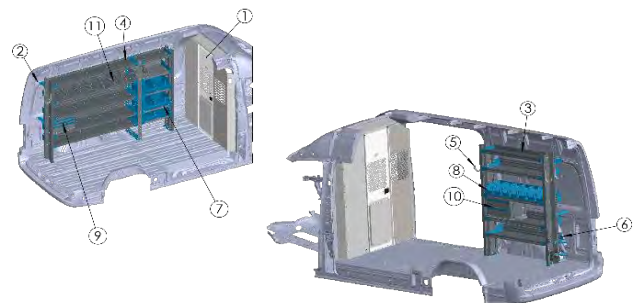

Adrian NextGen Trade Packages / Mercedes Sprinter 144" WB - High Roof

Driver Side - Long



Part Number: AS-2T1690SPHA
Description: 5-Shelf Unit, 16x90 (R66/F24)

Single Shelf Add-On Parts

AECK2T14A1 14" End Cap Kit, Single
 ASFK2T1466G1 Shelf, 14 x 66
 ASFK2T1424G1 Shelf, 14 x 24
 ACSI14A1 14" Center Support Kit, Single Shelf

Driver Side - Tank Rack



Part Number: AS-2T1484SPHA
Description: 5-Shelf Unit, Tank Rack & cabinet Use, 14x84 (R60/F24)

Single Shelf Add-On Parts

AECK2T14A1 14" End Cap Kit, Single
 ASFK2T1460G1 Shelf, 14 x 60
 ASFK2T1424G1 Shelf, 14 x 24
 ACSI14A1 14" Center Support Kit, Single Shelf

Passenger Side - Long



Part Number: AS-2T1454SPHA
Description: 5-Shelf Unit, 14x54

Single Shelf Add-On Parts

AECK2T14A1 14" End Cap Kit, Single
 ASFK2T1454G1 Shelf, 14 x 54

Passenger Side - Short



Part Number: AS-2T1442SPHA
Description: 5-Shelf Unit, Tank Rack Use, 14x42

Single Shelf Add-On Parts

AECK2T14A1 14" End Cap Kit, Single
 ASFK2T1442G1 Shelf, 14 x 42

Rail Kits



Part Number: ARKSP144 Mounting Rail Kit, Driver & Passenger Side
 ARKSP144DS Mounting Rail Kit, Driver Side
 ARKSP144PS Mounting Rail Kit, Passenger Side

All listed shelving units are 14" deep / 16" Deep shelves also available

"Short" units allow room at the rear of the vehicle to install accessories like tank racks.

"Long" units fill the maximum available length of the driver or passenger side to eliminate dead space.

Adrian NextGen Trade Packages / Mercedes Sprinter 170" WB - High Roof

Base Shelving Package, Sprinter High Roof 170" - BASE-SP-HR170

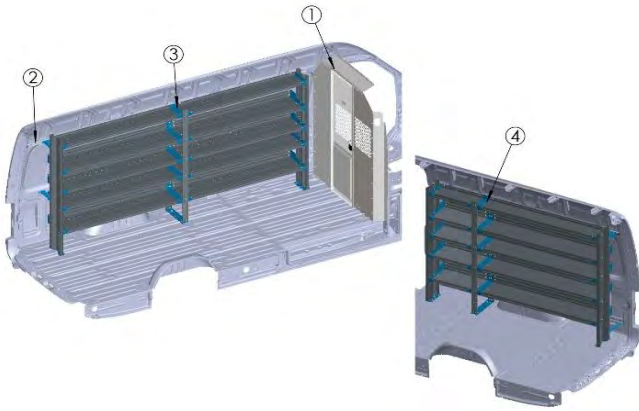

Bin Shelving Package, Sprinter High Roof 170" - BIN-SP-HR170

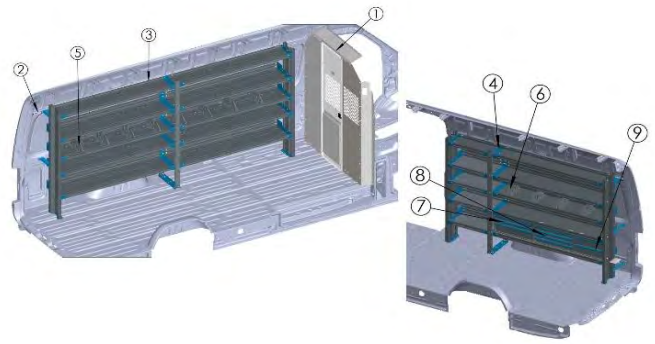

General Service Package, Mercedes Sprinter High Roof 170", GEN-SPHR170B

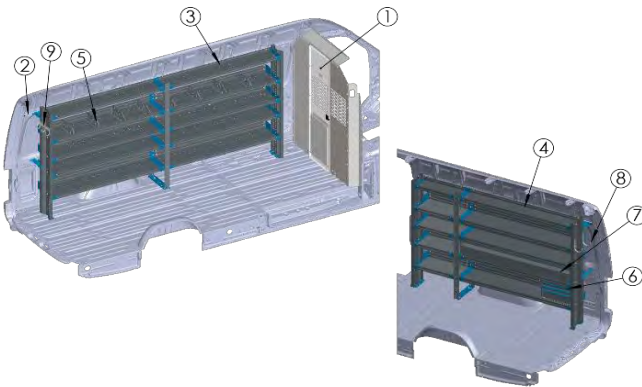

HVAC Essentials Package, Mercedes Sprinter High Roof 170", HVAC-SPHR170B

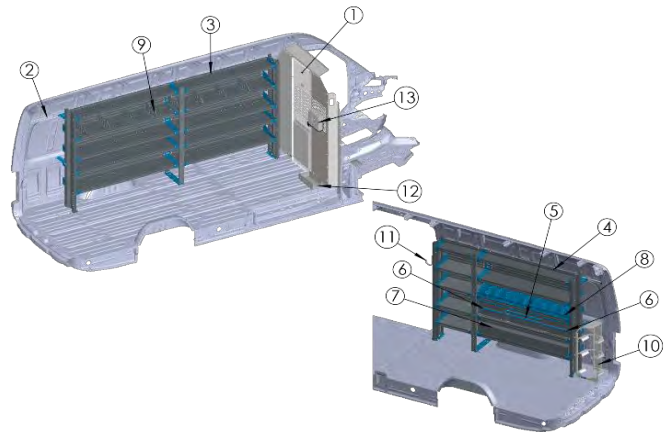

Electrical Essentials Package, Mercedes Sprinter High Roof 170", ELE-SPHR170B

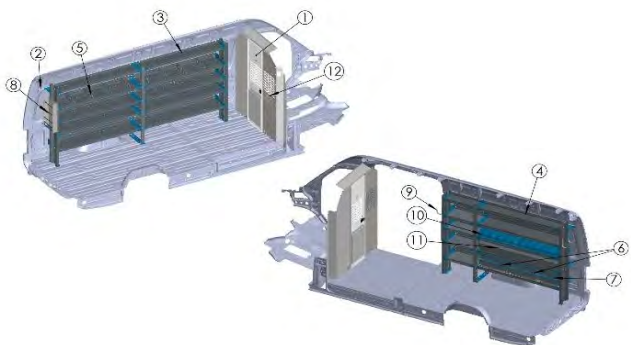

Plumbing Essentials Package, Mercedes Sprinter High Roof 170", PLUM-SPHR170B

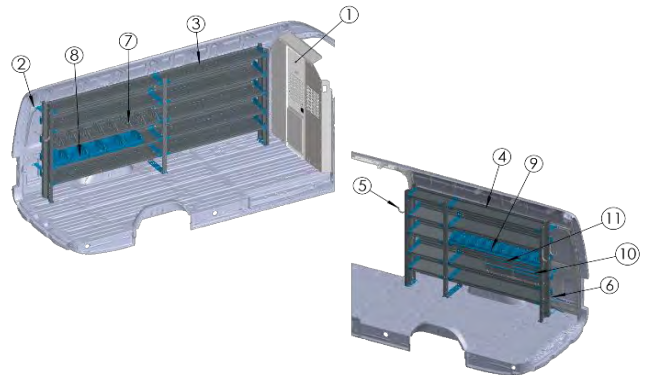

Adrian NextGen Trade Packages / Mercedes Sprinter 170" WB - High Roof

Driver Side - Cabinet



<u>Part Number:</u>	<u>Description:</u>
AS-2T14120SPHA	5-Shelf Unit, Cabinet Use, 14x120 (R60/F60)
Single Shelf Add-On Parts	
AECK2T14A1	14" End Cap Kit, Single
ASFK2T1460G1	Shelf, 14 x 60
ASFK2T1460G1	Shelf, 14 x 60
ACSK14A1	14" Center Support Kit, Single Shelf

Driver Side - Long



<u>Part Number:</u>	<u>Description:</u>
AS-2T14132SPHA	5-Shelf Unit, 14x132 (R66/F66)
Single Shelf Add-On Parts	
AECK2T14A1	14" End Cap Kit, Single
ASFK2T1466G1	Shelf, 14 x 66
ASFK2T1466G1	Shelf, 14 x 66
ACSK14A1	14" Center Support Kit, Single Shelf

Driver Side - Tank Rack



<u>Part Number:</u>	<u>Description:</u>
AS-2T14126SPHA	5-Shelf Unit, Tank Rack Use, 14x126 (R66/F60)
Single Shelf Add-On Parts	
AECK2T14A1	14" End Cap Kit, Single
ASFK2T1466G1	Shelf, 14 x 66
ASFK2T1460G1	Shelf, 14 x 60
ACSK14A1	14" Center Support Kit, Single Shelf

Passenger Side - Long



<u>Part Number:</u>	<u>Description:</u>
AS-2T1490SPHA	5-Shelf Unit, 14x90 (R66/F24)
Single Shelf Add-On Parts	
AECK2T14A1	14" End Cap Kit, Single
ASFK2T1466G1	Shelf, 14 x 66
ASFK2T1424G1	Shelf, 14 x 24
ACSK14A1	14" Center Support Kit, Single Shelf

Passenger Side - Short



<u>Part Number:</u>	<u>Description:</u>
AS-2T1484SPHA	5-Shelf Unit, Tank Rack & cabinet Use, 14x84 (R60/F24)
Single Shelf Add-On Parts	
AECK2T14A1	14" End Cap Kit, Single
ASFK2T1460G1	Shelf, 14 x 60
ASFK2T1424G1	Shelf, 14 x 24
ACSK14A1	14" Center Support Kit, Single Shelf

Rail Kits



<u>Part Number:</u>	<u>Description:</u>
ARKSPH170DS	Mounting Rail Kit, Driver Side
ARKSPH170PS	Mounting Rail Kit, Passenger Side
ARKSPH170	Mounting Rail Kit, Driver & Passenger Side

All listed shelving units are 14" deep / 16" Deep shelves also available

"Short" units allow room at the rear of the vehicle to install accessories like tank racks.

"Long" units fill the maximum available length of the driver or passenger side to eliminate dead space.

Adrian NextGen Trade Packages / Mercedes Sprinter 170" Ext. WB - High Roof

Base Shelving Package, Sprinter High Roof 170"X - BASE-SP-HR170X

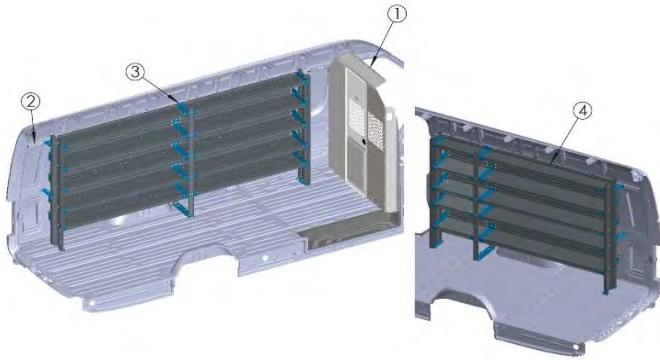

Bin Shelving Package, Sprinter High Roof 170"X - BIN-SP-HR170X

No Image Available

General Service Package, Mercedes Sprinter High Roof 170" Extended, GEN-SPHR170XB

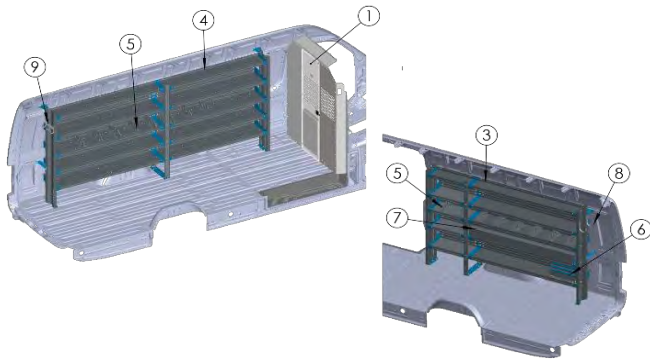

HVAC Essentials Package, Mercedes Sprinter High Roof 170" Extended, HVAC-SPHR170XB

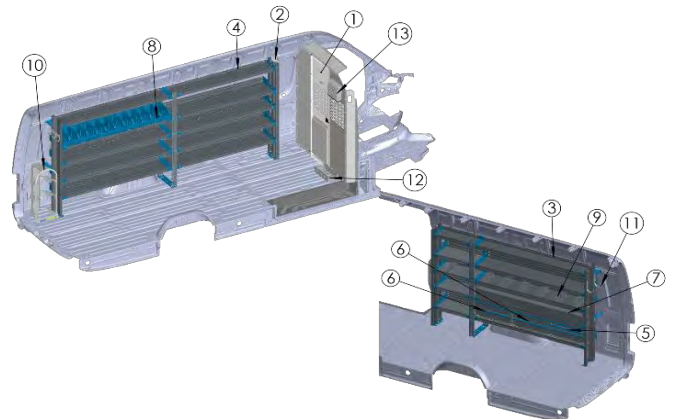

Electrical Essentials Package, Mercedes Sprinter High Roof 170" Extended, ELE-SPHR170XB

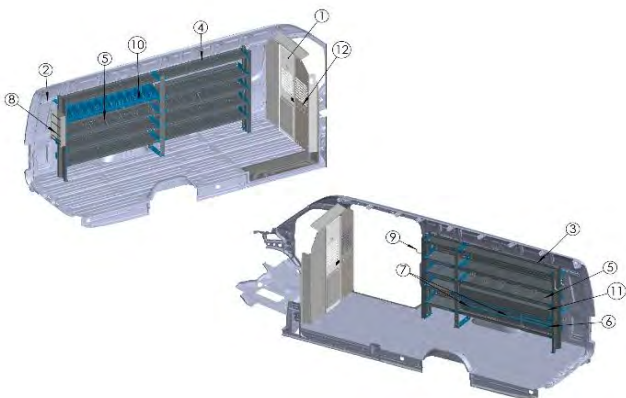

Plumbing Essentials Package, Mercedes Sprinter High Roof 170" Extended, PLUM-SPHR170XB

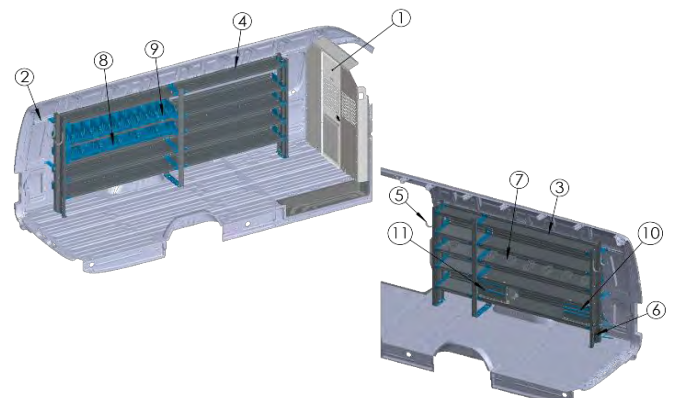

Adrian NextGen Trade Packages / Mercedes Sprinter 170" Ext. WB - High Roof

Driver Side - Long



Part Number:

AS-2T14138SPHA

Description:

5-Shelf Unit, Tank Rack & Cabinet Use, 14x138 (R72/F66)

Single Shelf Add-On Parts

AECK2T14A1

14" End Cap Kit, Single

ASFK2T1472G1

Shelf, 14 x 72

ASFK2T1466G1

Shelf, 14 x 66

ACSK14A1

14" Center Support Kit, Single Shelf

Driver Side - Tank Rack



Part Number:

AS-2T14138SPHA

Description:

5-Shelf Unit, Tank Rack & Cabinet Use, 14x138 (R72/F66)

Single Shelf Add-On Parts

AECK2T14A1

14" End Cap Kit, Single

ASFK2T1472G1

Shelf, 14 x 72

ASFK2T1466G1

Shelf, 14 x 66

ACSK14A1

14" Center Support Kit, Single Shelf

Passenger Side - Long



Part Number:

AS-2T1496SPHA

Description:

5-Shelf Unit, Tank Rack Use, 14x96 (R72/F24)

Single Shelf Add-On Parts

AECK2T14A1

14" End Cap Kit, Single

ASFK2T1472G1

Shelf, 14 x 72

ASFK2T1424G1

Shelf, 14 x 24

ACSK14A1

14" Center Support Kit, Single Shelf

Passenger Side - Short



Part Number:

AS-2T1496SPHA

Description:

5-Shelf Unit, Tank Rack Use, 14x96 (R72/F24)

Single Shelf Add-On Parts

AECK2T14A1

14" End Cap Kit, Single

ASFK2T1472G1

Shelf, 14 x 72

ASFK2T1424G1

Shelf, 14 x 24

ACSK14A1

14" Center Support Kit, Single Shelf

Rail Kits



Part Number:

ARKSPH170X

Description:

Mounting Rail Kit, Driver & Passenger Side

ARKSPH170XDS

Mounting Rail Kit, Driver Side

ARKSPH170XPS

Mounting Rail Kit, Passenger Side

All listed shelving units are 14" deep / 16" Deep shelves also available

"Short" units allow room at the rear of the vehicle to install accessories like tank racks.

"Long" units fill the maximum available length of the driver or passenger side to eliminate dead space.

Adrian NextGen Trade Packages / Mercedes Sprinter Dimensions

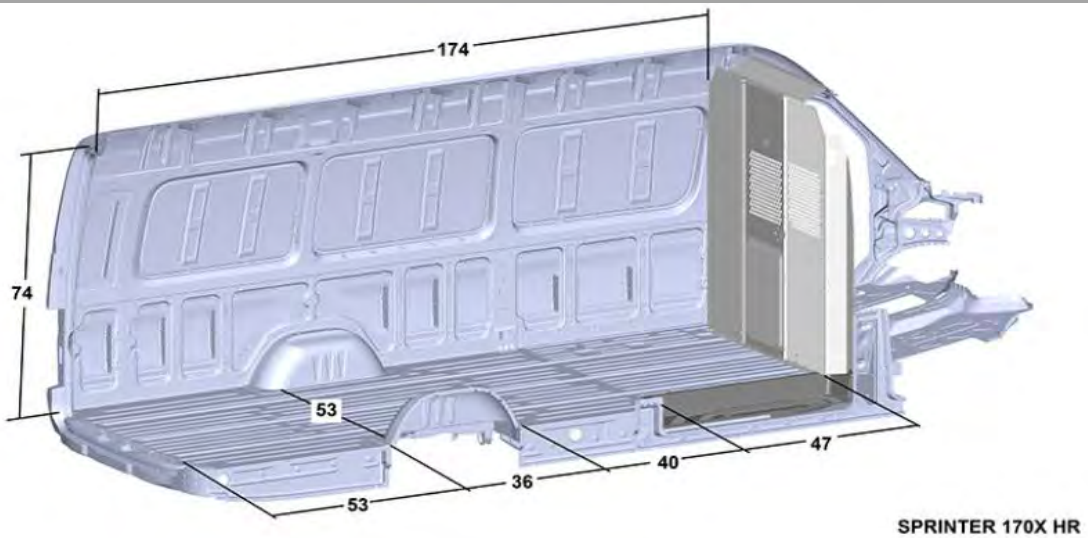
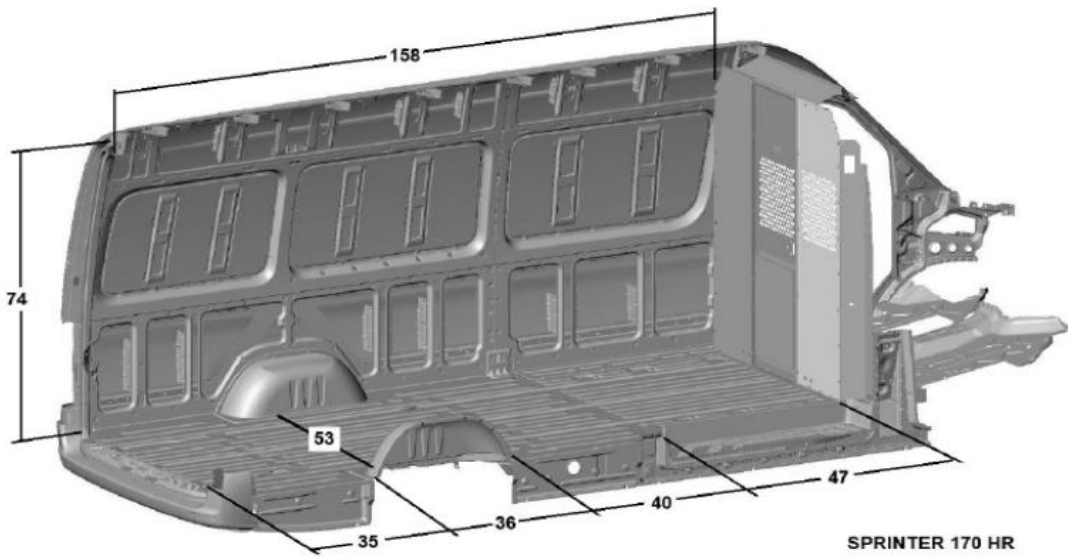
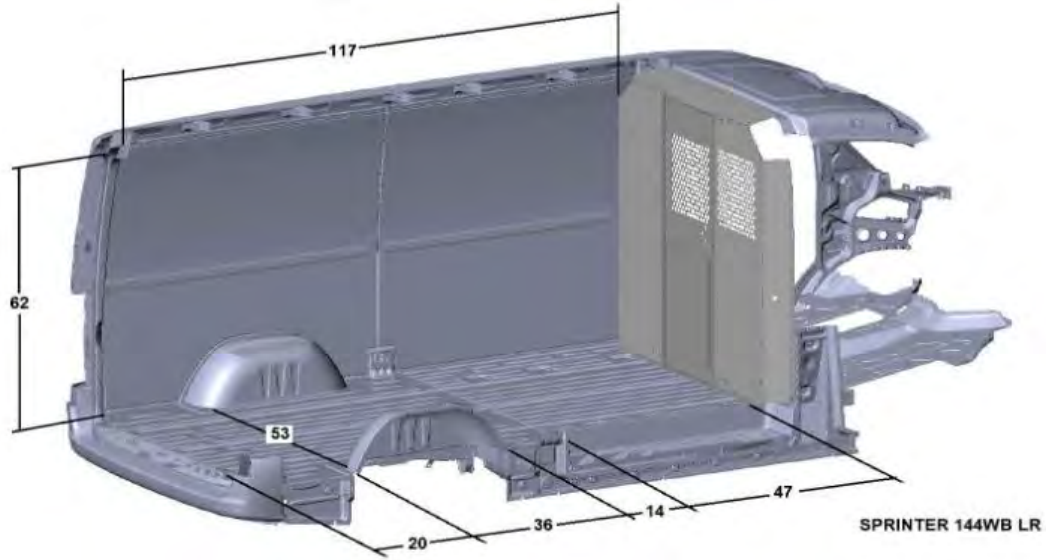

Adrian NextGen Shelving Accessories / 14" Deep

Drawer Units - 18" W



Part Number:

ADUK1418A2T-RI
ADUK1418A3C-RI
ADUK1418A4S-RI

Description:

2-Drawer Unit w/ Risers, 14 x 18
3-Drawer Unit w/ Risers, 14 x 18
4-Drawer Unit w/ Risers, 14 x 18

Drawer Units - 24" W



Part Number:

ADUK1424A2T-RI
ADUK1424A3C-RI
ADUK1424A4S-RI

Description:

2-Drawer Unit w/ Risers, 14 x 24
3-Drawer Unit w/ Risers, 14 x 24
4-Drawer Unit w/ Risers, 14 x 24

Door Kits



Part Number:

ADK1024A
ADK1030A
ADK1036A
ADK1042A
ADK1048A
ADK1054A
ADK1060A
ADK1066A
ADK1072A

Description:

Shelf Door Kit, 10 x 24
Shelf Door Kit, 10 x 30
Shelf Door Kit, 10 x 36
Shelf Door Kit, 10 x 42
Shelf Door Kit, 10 x 48
Shelf Door Kit, 10 x 54
Shelf Door Kit, 10 x 60
Shelf Door Kit, 10 x 66
Shelf Door Kit, 10 x 72

Portable Bins



Part Number:

906BIN614
906BIN1214

Description:

6" Portable Bin
12" Portable Bin

Shelf Dividers



Part Number:

DIVK141
DIVK144
DIVK148

Description:

14" Shelf Divider, Single
14" Shelf Divider, 4-Pack
14" Shelf Divider, 8-Pack

Adrian NextGen Flooring

Designed to fit your vehicle and support our Next-Gen Shelving and Accessories, these floors act as the first line of defense for your investment.

Part Number:

MFKMS144
MFKMS170
MFKMS170X

Description:

Mercedes Sprinter 144"
Mercedes Sprinter 170"
Mercedes Sprinter 170" Extended

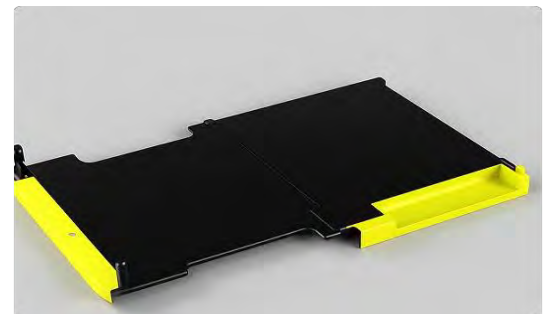

Adrian NextGen Shelving Accessories / Tank Racks

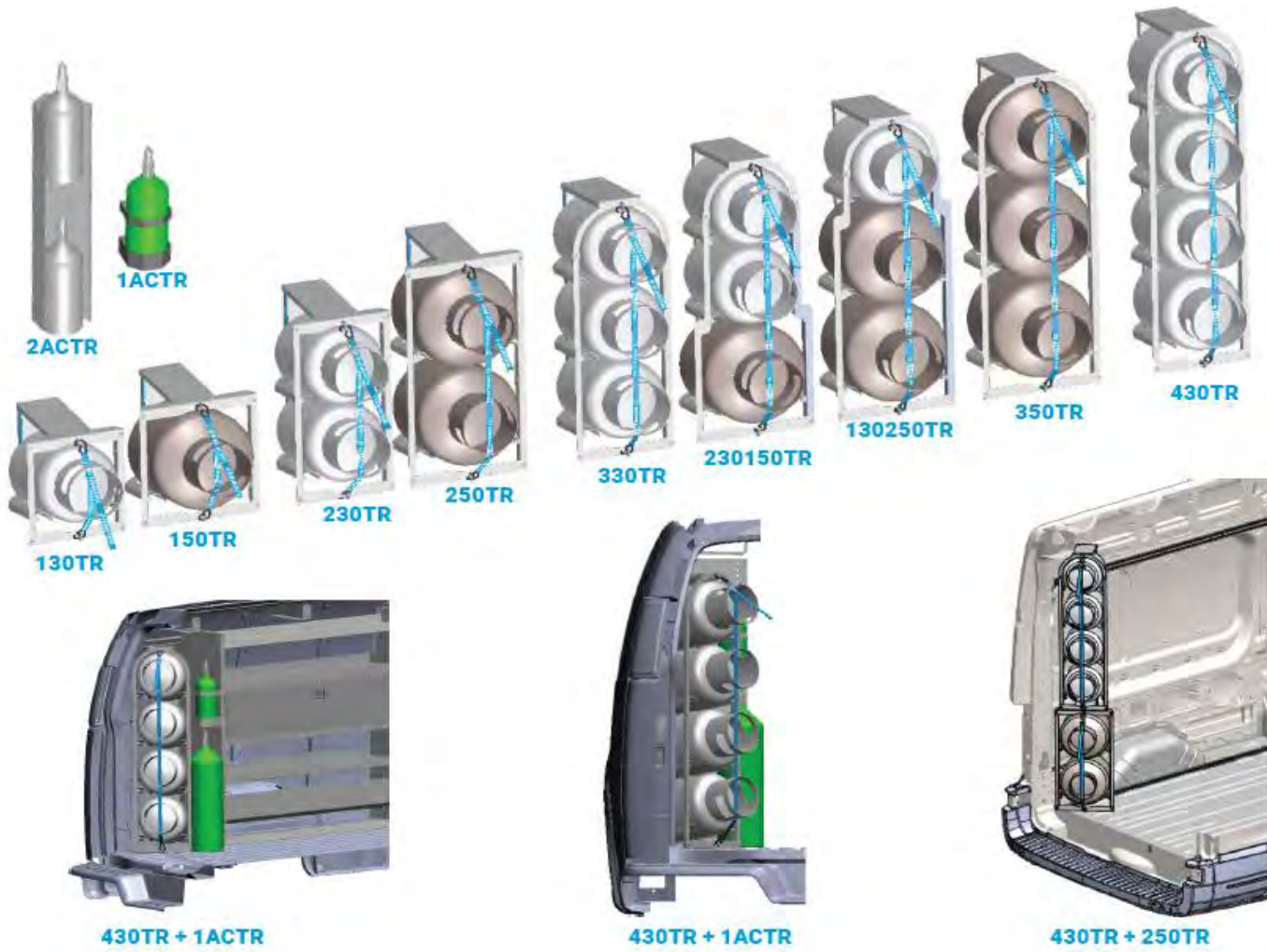

Model	Desc.
1ACTR	1-Acetylene Tank Holder
2ACTR	2-Acetylene Tank Holder
130TR	EZLoad™ Tank Rack, 30lb. (1)
150TR	EZLoad™ Tank Rack, 50lb. (1)
230TR	EZLoad™ Tank Rack, 30lb. (2)
250TR	EZLoad™ Tank Rack, 50lb. (2)
330TR	EZLoad™ Tank Rack, 30lb. (3)
230150TR	EZLoad™ Tank Rack, 30lb. (2), 50lb. (1)
130250TR	EZLoad™ Tank Rack, 30lb. (1), 50lb. (2)
350TR	EZLoad™ Tank Rack, 50lb. (3)
430TR	EZLoad™ Tank Rack, 30lb. (4)

MOUNT AT THE REAR OR SIDE DOORS FOR SAFEST AND EASIEST ACCESS.

SAFEST ERGONOMIC ANGLE

This system is designed to be installed at the rear or side doors providing you the most ergonomic access to your tanks. This helps prevent back and shoulder injuries when loading/unloading full or empty

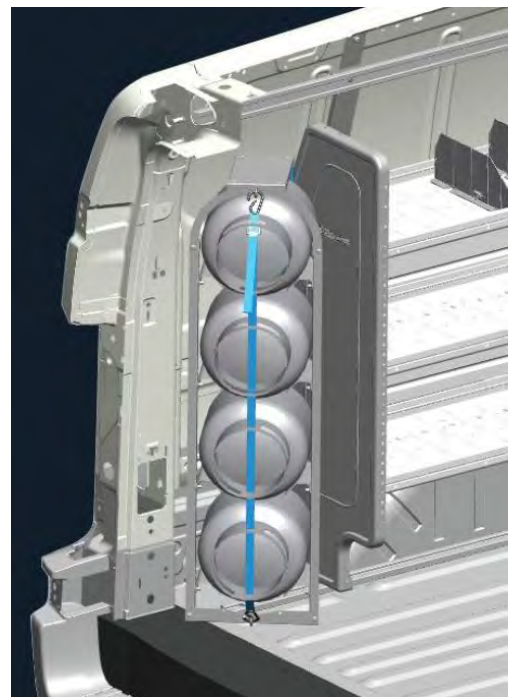

Adrian Composite Partitions - Mercedes Sprinter



Molded fit for a tighter seal

Designed to fit the contours of your specific vehicle, the tighter seal provides you with increased climate control in the cab, more odor and debris control from the cargo area and better sound control to reduce the noise from the cargo area into the cab while you're driving.



Accessory rail kits

Utilize your partition as valuable storage space for quick and easy access to frequently used items. For safety purposes, mount emergency items like fire extinguishers, reflector kits and First Aid kits right to the partition itself.



Incorporated 3" setback

Get an increased seat recline angle to improve comfort while driving.



Available with or without a window

If your vehicle has side or rear van door windows, we offer an option with an angled polycarbonate window to prevent glares and reduce blind spots.

Low Roof Composite Partition

(with and without window)



High Roof Composite Partition

(with and without window)



MERCEDES	With Visibility	Without Visibility
Sprinter Low Roof 144"	PARSPL	PARSPL-NW
Sprinter High Roof 170" & 170" Extended	PARSPH	PARSPH-NW

Adrian Steel Partitions - Mercedes Sprinter



Perforated Panels

Perforations allow you to see through the partition to check your cargo or use vehicle windows to reduce blind spots.

They allow heat/air to travel into the cargo area.



Optional 3" Setback

Get an increased seat recline angle to improve comfort while driving.

Not available for Ford Transit.



Accessory Storage

Utilize your partition as valuable storage space for quick and easy access to frequently used items.



Optional Door Kit

Door kits are great for those who need to access their cargo area frequently and want to reduce stepping up and down to get into the back of the vehicle.

Solid Steel Partition Panel Kit for Full-Size Vans



Steel Partition Panel Kit w/ Visibility for Full-Size Vans



Steel Partition Panel Kit w/ Full Visibility for Full-Size Vans



Mercedes	Partition Mounting Kits	Partition Mounting Kits with 3" Setback	Solid	Solid With Door	Visibility	Visibility with Door
Sprinter Low Roof 144"	<i>n/a</i>	<i>n/a</i>	S1M1C1SPS2	S1M1HC1SPS	S1M2C1SPS2 S1M2C2SPS2 S2M2C2SPS2	S1M2HC1SPS S1M2HC2SPS S2M2HC2SPS
Sprinter High Roof 170" & 170" Extended	<i>n/a</i>	<i>n/a</i>	S1M1C1SPH2	S1M1HC1SPH	S1M2C1SPH2 S1M2C2SPH2 S2M2C2SPH2	S1M2HC1SPH S1M2HC2SPH S2M2HC2SPH

**Mercedes Sprinter 144" WB High Roof
General Service 600-8451R**



**Mercedes Sprinter 144" WB High Roof
Cable/Plumber 600-8452R**



**Mercedes Sprinter 144" WB High Roof
Electrical 600-8454R**



**Mercedes Sprinter 144" WB High Roof
Commercial 600-8450R**



**Mercedes Sprinter 144" WB High Roof
HVAC 600-8453R**



All shown packages are available in all roof & length configurations

**Mercedes Sprinter 170" WB High Roof
General Service 600-8451L**



**Mercedes Sprinter 170" WB High Roof
Cable/Plumber 600-8452L**



**Electrical Contractor Van Package, High-Roof, RAM
ProMaster**



**Mercedes Sprinter 170" WB High Roof
Commercial 600-8450L**



**Mercedes Sprinter 170" WB High Roof
HVAC 600-8453L**



All shown packages are available in all roof & length configurations

Weather Guard - Van Items

Folding Shelves

What you carry every day can change on a dime, so we built WEATHER GUARD Folding Shelves to offer the ultimate in van storage flexibility. Flip them up for larger loads or fold them down for longer, bulkier packages. Each shelf features removable endcaps so you can convert two shelves into one continuous work surface for longer items. The lightweight, rust-free aluminum construction makes them easy to operate with one hand, but strong enough to carry a 300 lb. load.

Our new folding shelves are easy to install and can be assembled in less than 15 minutes. Plus, they are compatible with WEATHER GUARD rail mounting systems so you can mix and match with our standard shelf units or upgrade your whole work van.



FEATURES AND BENEFITS

- Mix and match with static shelves for versatile van upfits
- One-handed operation
- Lightweight, but durable. Can handle loads up to 300 lbs.
- White and bright coating helps lighten up dark van spaces
- Available for most mid- and high-roof vans



Flooring Solutions

Your work van goes through a lot every day, and the floor takes the biggest hit. That's where WEATHER GUARD rigid flooring comes in. Built to last the lifetime of your upfit, its flat, non-slip surface and Hi-Viz sills to keep you steady and safe all day long.

FEATURES

- ✓ Non-slip grip and hi-visibility, no-slip red sills for extra safety when entering and exiting the van
- ✓ The only rigid flooring tough enough to earn the WEATHER GUARD badge and a Limited Lifetime Warranty



RFMS44-5-01 Rigid Flooring with Sills, 144in WB

RFMS70-5-01 Rigid Flooring with Sills, 170in WB

RFMS70E-5-01 Rigid Flooring with Sills, 170in Extended WB

Partitions / Bulkheads



- ✓ **Steel**
Available with or without passthrough door
- ✓ **Composite**
Improved climate control and noise reduction

Van bulkheads separate the driver compartment from the cargo area for maximum protection against shifting or moving cargo. Compliant to FMVSS safety standards for cargo vans.

Storage Solutions

✓ Lockable Cabinets



✓ Between the seat desks



✓ Part Cases



✓ Door Trays



✓ Caulk Tube Holder

✓ Literature Holders



Shelving Solutions



- ✓ **Fixed or Adjustable Shelves**
- ✓ **Multiple Heights**
- ✓ **Multiple Widths**
- ✓ **Bin Accessories**

Adjustable cargo van shelving is deeper to hold more tools and equipment and has captive nuts at each corner for easier assembly and quieter operation. Fully hemmed work van shelving for extra strength and durability. Accessory mounting holes in the commercial van shelving eliminates the need for mounting brackets or drilling.

Weather Guard - Van Items

Storage Solutions

ALL-NEW WEATHER GUARD PACK RAT

Not just a drawer system; this is the steel-built solution to everything plastic gets wrong. While others crack and warp, PACK RAT stands strong and keeps your tools protected.

- ✓ Fleet-ready 1KEY ULTRALOCK™: the ultimate truck toolbox lock system for pros and fleet managers who demand speed, security, and simplicity
- ✓ 14-gauge steel construction resists break-ins and harsh conditions
- ✓ 425 lbs. drawer capacity
- ✓ Up to 2,000 lbs. top-load rating
- ✓ Customizable partitions and dividers for secure organization
- ✓ 40% more secure storage than comparable systems



- ✓ Available in
 - White or Black
 - Multiple Widths
 - Multiple Lengths
 - Multiple Drawers



Storage Accessories

✓ Tank Racks



✓ Wire Holders



✓ Ends for PVC Pipe Conduit Storage



✓ Parts Bins



✓ Window Screens

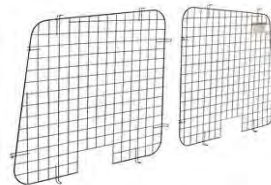
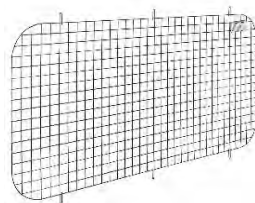

✓ Shelf Mat



✓ Parts Cases



✓ Conduit Carriers



✓ Grab Handles



✓ Storage Hooks



Quick Package Go - Sprinter 144" WB High Roof
PART#: FFG-SRH

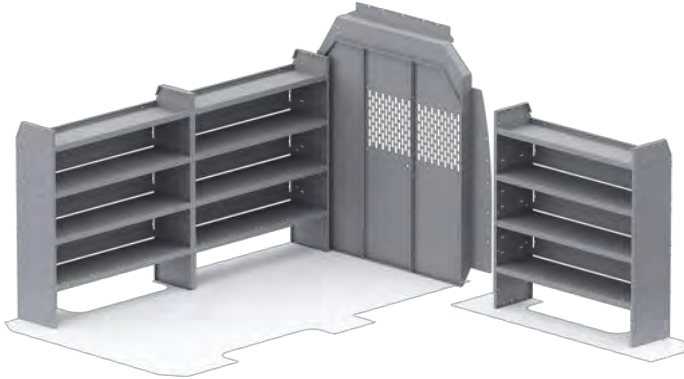

Plumbing Van Package - Sprinter High Roof 144" Wheelbase PART#: 55SRH



Electrical Contractor Van Package - Sprinter High Roof 144" Wheelbase PART#: 53SRH



HVAC Van Package - Sprinter High Roof 144" Wheelbase PART#: 54SRH



Locksmith Van Package - Sprinter High Roof 144" Wheelbase PART#: 50SRH

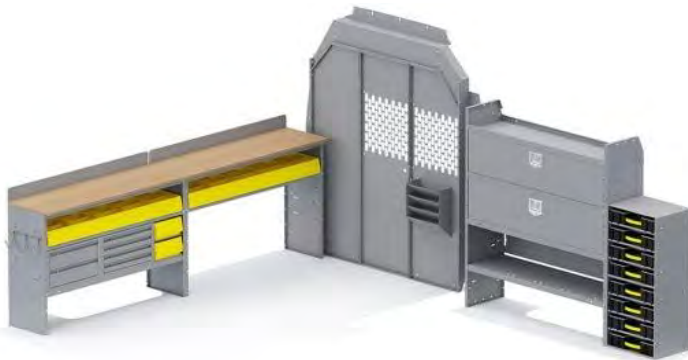

Folding Shelves Package - Sprinter 144" WB High Roof - Sliding Partition PART#: 51SRH



All shown packages are available in all roof & length configurations

Quick Package Go - Sprinter 170" WB High Roof
PART#: FFG-SLH

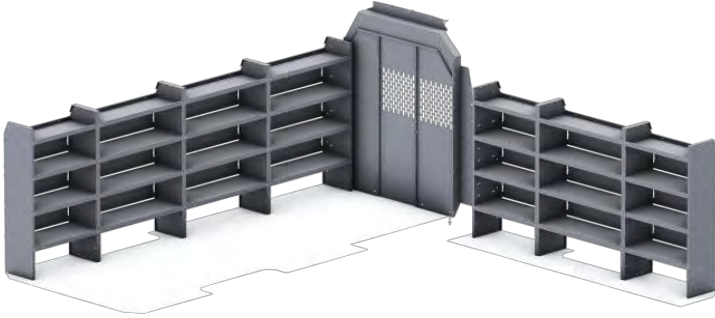

Plumbing Van Package - Sprinter High Roof 170" Wheelbase PART#: 55SLH

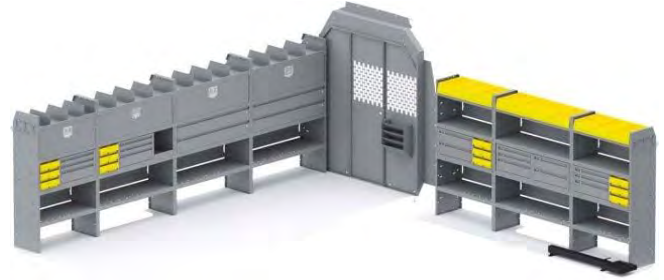

Electrical Contractor Van Package - Sprinter High Roof 170" EXT Wheelbase PART#: 53SEH

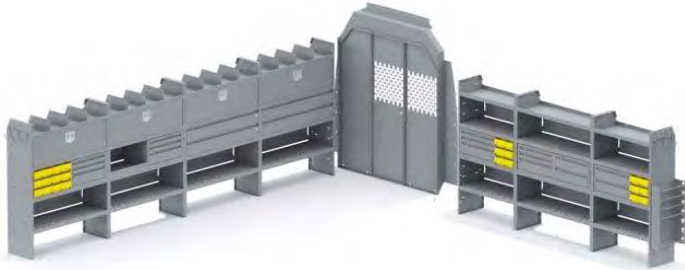

HVAC Van Package - Sprinter High Roof 170" EXT Wheelbase PART#: 54SEH

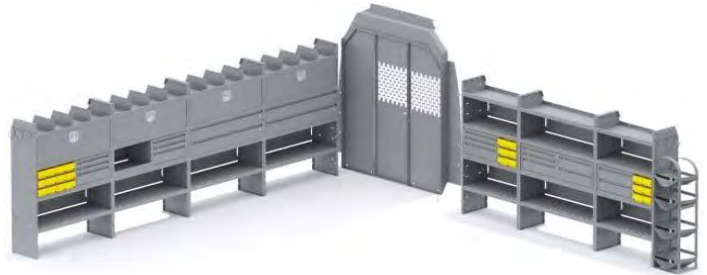

Locksmith Van Package - Sprinter High Roof 170" Wheelbase PART#: 50SLH



Folding Shelves Package - Sprinter 170" WB High Roof - Sliding Partition PART#: 51SLH



All shown packages are available in all roof & length configurations

Holman - Van Items

Partitions / Bulkheads

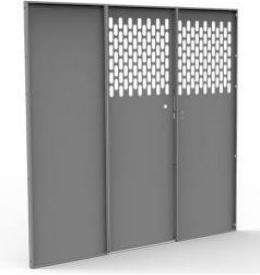

**PARTITION KIT
PERFORATED SPRINTER
STD ROOF
PART#: 4061SL**



**PARTITION WING KIT
SPRINTER STD ROOF
PART#: 406SL**



**PARTITION KIT
PERFORATED -
SPRINTER HIGH ROOF
PART#: 4061SH
(Includes Wing Kit)**

Shelving Solutions



**Shelf Unit - 32" W x 60" H x 14" D
ID: 48324**



**Shelf Unit - 42" W x 60" H x 14" D
ID: 48424**



**Shelf Unit - 52" W x 60" H x 14" D
ID: 48524**

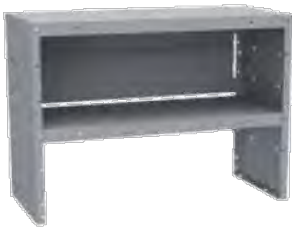

**Shelf Unit - 32" W x 27" H x 14" D
ID: 48322**



**Shelf Unit - 52" W x 27" H x 14" D
ID: 48522**



**Shelf Unit - 32" W x 36" H x 14" D
ID: 48323**



**Shelf Unit - 42" W x 27" H x 14" D
ID: 48422**



**Shelf Unit - 42" W x 36" H x 14" D
ID: 48423**



**Shelf Unit - 52" W x 36" H x 14" D
ID: 48523**

STORAGE SOLUTIONS

From lockers and cabinets to locking drawers, our customizable storage solutions give you peace of mind that your tools, parts, and equipment will always be where you leave them.



Shelf Door Kit



Locking Shelf Drawer



Drawer Cabinet



Locking Cabinet

PARTS ORGANIZATION

Choose from a wide variety of bins and Cargo Case storage options so everything stays where you put it.



Small Parts Bin



Cargo Case Holder



Cargo Case



Bin Holder

TRADE

No matter your trade, we have what you need.



Wire Wheel Holder



Tank Holder



Work Bench



UP TO 50% LIGHTER OPERATION

The ProLift™ is up to 50% easier to operate than comparable drop-down style ladder racks. This makes it the easiest and safest drop-down ladder rack system on the market. Using unique patent pending mechanical advantages and high-performance spring assist strut, ProLift™ raises and lowers ladders with an almost effortless pull, saving you time and energy while reducing back and shoulder injuries.

Built on Adrian Steel's new flagship Profile™ rack system, the ProLift™ is low profile, lightweight and built to last.

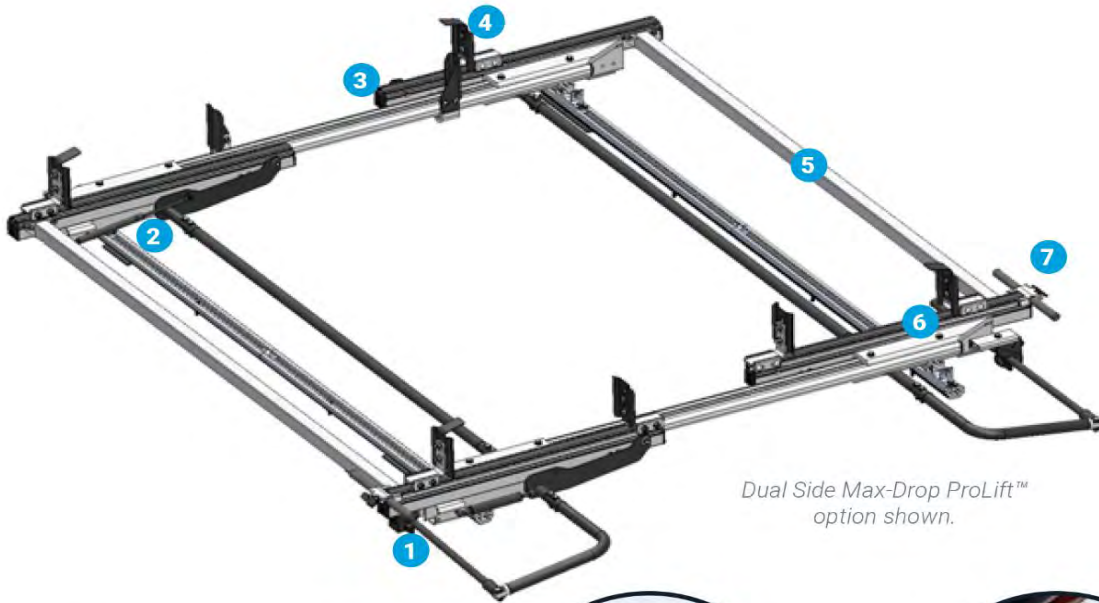

Dual Side Max-Drop ProLift™ option shown.

- 1 LOCKABLE ATTACHED HANDLE**
Prevents losing your ladder rack handle and wasting time obtaining a new one. Pad-Lock capable to prevent theft.
- 2 PULL ASSIST GAS SPRINGS**
Dampens the load during operation to prevent damage to the vehicle while also reducing operating force.
- 3 RUGGED WEAR STRIPS**
Protects and helps increase the life of your ladders.
- 4 ADJUSTABLE CLAMP PADS**
Get a snug fit on any ladder with just a half inch wrench or ratchet/socket.
- 5 LADDER GUIDE / VAN GUARD**
Help guide the ladder into the front bracket while also preventing damage to the van from the ladder.
- 6 SECONDARY SLIDE (MAX-DROP)**
The secondary slide lowers the ladder to a lower more ergonomic reach height to prevent back and shoulder injuries during operation.
- 7 EASY RELEASE T-HANDLE (MAX-DROP)**
Press and release with thumb to active the secondary slide.



Adrian PROFILE Series - ProLift Ladder Rack



Mechanically Load Ladders

Using unique mechanical advantage and high-performance spring assist struts to raise ladders with little effort.



Minimalistic Design

A sleek, low-profile design, specifically engineered and tested to prevent wind noise, is a great-looking integration on any vehicle.



No Drill Installation

Using OEM mounting locations on the roof, this rack is easy to install with no drilling required.



Ladder Protection and Security

Four clamp pads provide peace-of-mind that your ladders will remain secure during your commute. You can also add a padlock to protect your ladder from theft.



Ladder Compatibility

Fits extension ladders up to 34' and step/podium ladders up to 8'. Easily operates with up to 100 lbs per lift.



Corrosion Resistant

All components are aluminum with a plastisol or powder-coat finish to withstand the elements and help prevent rust.

OEM	Vehicle	Standard-Drop			Max-Drop		
		Passenger Side ProLift	Dual Side ProLift	Combo ProLift & Grip-Lock	Passenger Side ProLift	Dual Side ProLift	Combo ProLift & Grip-Lock
Sprinter	Sprinter Low Roof	–	–	–	PLM61SP	PLM63SP	–
	Sprinter Low Roof w/ OEM Rail	–	–	–	PLM61SPO	PLM63SPO	–
	Sprinter High Roof	–	–	–	PLM61SPH	PLM63SPH	–
	Sprinter High Roof w/ OEM Rail	–	–	–	PLM61SPHO	PLM63SPHO	–

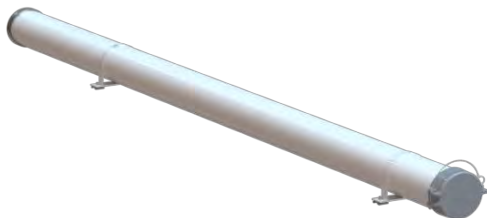

	Part Number:	Description:
Full Kit	70-1NGLR	4" End Caps for PVC Conduit Kit / Pipe NOT included
Full Kit	70-2NGLR	6" End Caps for PVC Conduit Kit / Pipe NOT included
Full Kit	80-1NGLR	10'6" Aluminum Conduit Kit
Full Kit	80-2NGLR	12'6" Aluminum Conduit Kit



Adrian Steel PROFILE™ HD Utility Rack.

The perfect rack for your business.

Select a pre-configured rack developed for common industry needs or take charge and build your own with our configuration tool.

This new system is low profile, aerodynamic, lightweight & tough. The clean, simplistic and corrosion resistant construction with stainless steel hardware and durable powder-coat finish is built to withstand heavy use and ensure years of dependability.

Mix and match components and accessories give you the flexibility to get the perfect rack for your business in less time and with less hassle.

Designed to adapt to almost any vehicle (truck, trailer and topper mounting coming soon) and the unique modular design can be easily upgraded for specific utility use.

1. Minimalistic Design.

Sleek, low-profile for great looking integration on any vehicle and was specifically designed and tested to prevent wind noise.

2. Safe, Secure Loading.

Multiple integrated tie-down points come standard for quick and safe transportation.

3. Rugged Wear Strip.

Why let loading and unloading take a toll on your gear and rack systems? Our new, extra-thick Wear Strip comes standard to protect equipment and T-slot crossbars, while keeping debris out of the channels.

4. Industry-Leading Customization.

Profile™ Crossbars have built-in channels for adding Ladder Stops, Rear Roller Assist, Built-In Ratchets, Conduit Kits and additional accessories.

5. 750lb. Load Capacity.

3" x 1.5" Heavy Duty, reinforced extruded aluminum crossbars are tested to support up to 250LBS per crossbar for maximum roof loading capacity.

(Always follow OEM roof rating weight standards for safest loading capacity)

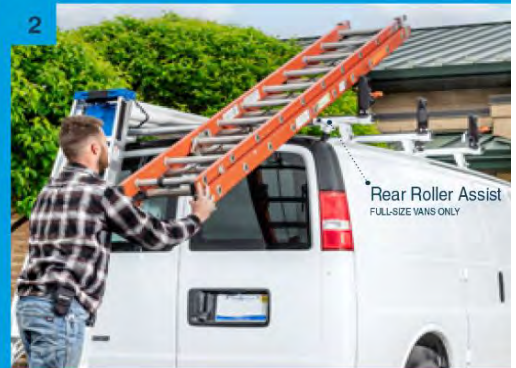

Adrian PROFILE - HD Utility Rack



The perfect rack for your business.

Select a pre-configured rack developed for common industry needs or take charge and build your own with our configuration tool.

1

2-BAR OPTIONS

How to Order: "2-Bar Part Number" + "4-Pack Mounting Kit"



2-Bar w/ 4" Uprights

Full-Size Van #. Compact Van #.

2B4W

2B4CW



2-Bar w/ 6" Uprights

Full-Size Van #. Compact Van #.

2B6W

2B6CW



2-Bar w/ 9" Ratchet Uprights

Full-Size Van #. Compact Van #.

2B9RW

2B9RCW

1

3-BAR OPTIONS

How to Order: "3-Bar Part Number" + "4-Pack Mounting Kit" + "2-Pack Mounting Kit"

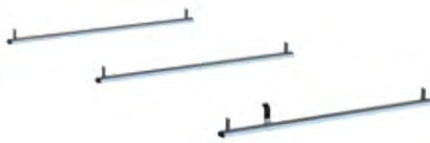

3-Bar w/ 4" Uprights

Full-Size Van #. Compact Van #.

3B4W

N/A



3-Bar w/ 6" Uprights

Full-Size Van #. Compact Van #.

3B6W

N/A



3-Bar w/ 9"⁽²⁾ & 9" Ratchet Uprights⁽⁴⁾

Full-Size Van #. Compact Van #.

3B9RW

N/A



3-Bar w/ 6" Uprights & Rear Roller

Full-Size Van #. Platform:

3B6RRFTW*

Transit

2

3

MOUNTING BRACKETS

4-Pack

2-Pack

Vehicle Platform:

Ford	FTMBK4W	FTMBK2W	Transit Low Roof
	FTMBK4W	FTMBK2W	Transit Mid/High Roof
	TCMBK4W	TCMBK2W	Transit Connect

What to order:

1

2

3

2-Bar Rack:

2-Bar Rack part number

+

4-Pack part number

3-Bar Rack:

3-Bar Rack part number

+

4-Pack part number

+

2-Pack part number

10'6" & 12'6" Aluminum Conduit Carriers



Part #:

80-1NGLR

80-2NGLR

Desc.

10'6" Aluminum Box

12'6" Aluminum Box



4" & 6" End Caps for PVC Conduit Carriers (PVC Pipe not included)

Part #:

70-1NGLR

70-2NGLR

Desc.

4" End Caps for PVC

6" End Caps for PVC



- ✓ Aluminum - Corrosion Resistant
- ✓ Unique oval rail design of the Safari Rack
- ✓ Accommodates up to 5-foot wide loads easily



- ✓ 2 or 3 Bar Racks
- ✓ Powder Coated Steel
- ✓ Fits vans with rain gutters



- ✓ 2 or 3 Bar Racks
- ✓ Aluminum
- ✓ 70" Wide

- ✓ QUICK CLAMP RACK
- ✓ Single or Dual Side Clamps
- ✓ Aluminum or Powder Coated Steel

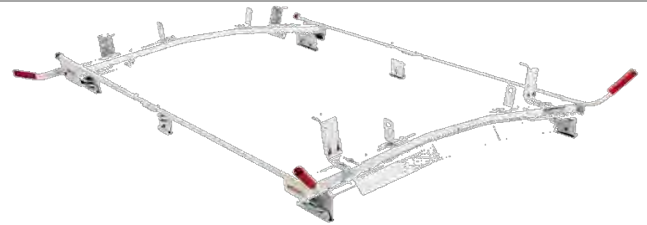

- ✓ EZGLIDE2™ Fixed Drop-down Ladder
- ✓ Single or Dual Side Drop Downs
- ✓ Powder Coated Steel



- ✓ Fits up to an 8-foot step, extension, or multi-position ladder
- ✓ Single or Dual Side Clamps
- ✓ Powder Coated Steel
- ✓ Mounts to the roof of the van
- ✓ Ladder weight should not exceed 80lbs.

PRIME DESIGN

ERGORACK® BENEFITS



Easy to use – deploys with only 2 fingers.



Eliminates slip and fall hazards from climbing on bumper or tire.



Improve productivity – Deploy or stow in less than 20 seconds.



Removable handle – easy access for operators of any height.



Maintain vehicle warranty and resale value with no holes to drill.



Control ladder deployment with adjustable hydraulic cylinder



Winner of ergonomic awards in USA, France, Germany and Australia.



Deter theft and secure contents with padlock ready handle



STEEL



ALUMINUM

their rust vs. Prime Design no rust



DRILLED



NO DRILL

competition vs. ErgoRack®



Lightweight, Safe and Easy

Prime Design has been the industry’s ergonomic leader since 1992, when we first introduced the concept of an ergonomic ladder rack.

Our design philosophy starts with the worker – how can we make the job safer, easier and more comfortable for the human body? That is because we firmly believe that a product’s design and how it impacts the user is every bit as important as the quality of materials and construction.

The ErgoRack was designed to reduce muscle stress, eliminate risk of injury and speed the job of loading and unloading ladders from a work van.

PRIME DESIGN™

ERGORACK® BENEFITS

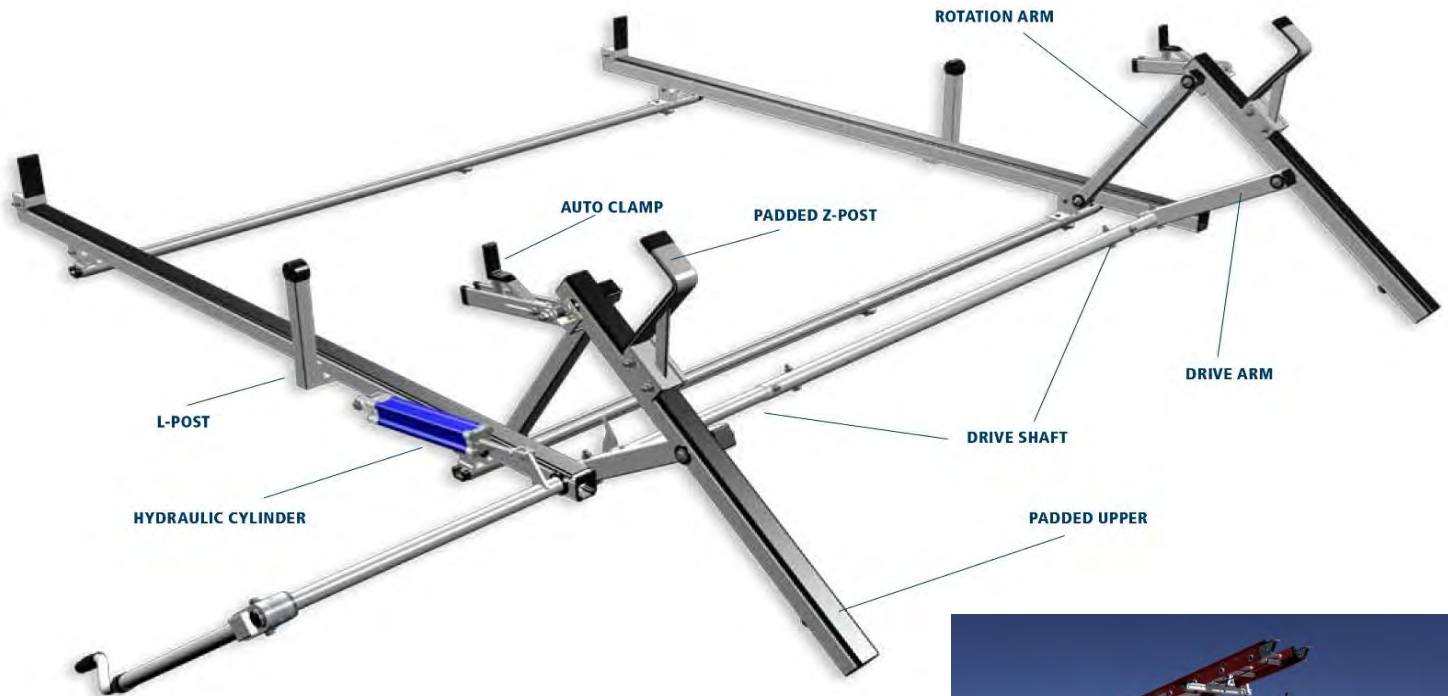

ErgoRack Configurations – Sprinter (without factory channels)
Modular (-M) and Hybrid Modular (-HM) are available depending on configuration.

Configuration	Vehicle Wheelbase	Vehicle Height	Streetside Feature	Curbside Feature
BB-SP-72	144 IN, 170 IN, or 170 Ext.	95 IN (Standard) or 106 IN (High)	End Stop	End Stop
BB3-SP-72*	144 IN, 170 IN, or 170 Ext.	95 IN (Standard) or 106 IN (High)	End Stop	End Stop
BR-SP-72	144 IN, 170 IN, or 170 Ext.	95 IN (Standard) or 106 IN (High)	End Stop	Rotation
RR-SP-72	144 IN, 170 IN, or 170 Ext.	95 IN (Standard) or 106 IN (High)	Rotation	Rotation
RR3-SP-72*	144 IN, 170 IN, or 170 Ext.	95 IN (Standard) or 106 IN (High)	Rotation (3 CBR)	Rotation

ErgoRack Models – Sprinter (with factory channels)

Configuration	Vehicle Wheelbase	Vehicle Height	Streetside Feature	Curbside Feature
BB-SPX-72	144 IN, 170 IN, or 170 Ext.	95 IN (Standard) or 106 IN (High)	End Stop	End Stop
BB3-SPX-72*	144 IN, 170 IN, or 170 Ext.	95 IN (Standard) or 106 IN (High)	End Stop	End Stop
BR-SPX-72	144 IN, 170 IN, or 170 Ext.	95 IN (Standard) or 106 IN (High)	End Stop	Rotation
RR-SPX-72	144 IN, 170 IN, or 170 Ext.	95 IN (Standard) or 106 IN (High)	Rotation	Rotation
RR3-SPX-72*	144 IN, 170 IN, or 170 Ext.	95 IN (Standard) or 106 IN (High)	Rotation (3 CBR)	Rotation

*Three crossbar rack

Prime Design - AluRack



AluRack

Aerodynamic and Lightweight

Work hard, look stylish and stay safe. The AluRack features the industry's original rolling bar, which makes it safe and easy to load bulky sheets of plywood, drywall, pipe and even weekend toys from the back of the truck. The lightweight, yet rugged design can carry all of your cargo and withstand challenging weather conditions. Plus, the aerodynamic design looks modern, reduces fuel consumption and ensures almost silent travel.



AluRack Models – Sprinter

Clear Anodized Models	Black Anodized Models	Vehicle Wheelbase	Vehicle Height	Crossbar Quantity	Crossbar Width
AR1928	AR1928-BLK	144 IN	99 IN	8	67"
AR1929	AR1929-BLK	144 IN	111 IN	8	59"
AR1930	AR1930-BLK	170 IN	111 IN	8	59"

Prime Design - Rear Door Access Ladder



Easily access cargo on the roof.

VEHICLE	ROOF HEIGHT	WHEELBASE	LENGTH	RUNGS	WEIGHT	MODEL
Ford Transit	84"– Low	All	54"	5	16 lbs.	AAL-8010
Ford Transit	101"– Medium	All	72"	7	18 lbs.	AAL-8009
Ford Transit	110"– High	All	78"	7	19 lbs.	AAL-8011
Mercedes Sprinter	99"– Standard	All	66"	6	16 lbs.	AAL-8004 †
Mercedes Sprinter	111"– High	All	78"	7	18 lbs.	AAL-8003 †
Nissan NV Cargo	84"– Low	All	54"	5	16 lbs.	AAL-8013
Nissan NV Cargo	106"– High	All	78"	7	18 lbs.	AAL-8014
RAM ProMaster	90"– Low	All	66"	6	17 lbs.	AAL-8012
RAM ProMaster	101"– High	All	72"	7	18 lbs.	AAL-8008
Chevrolet Express & GMC Savana	84"– Low	All	54"	5	16 lbs.	AAL-8015

Note: Bright anodized aluminum finish is standard. Optional Black anodized aluminum finish available. Add suffix "-BLK" to model number.

TOPPER - Van Racks

EST. 1975
INDUSTRIAL
TRUCK & VAN EQUIPMENT

Van Racks

Topper van racks utilize 100% of the available roof space, and our patented mounting system makes installation easy with no drilling of holes on full size vans. All of Topper van racks are made from high strength steel and hot dip galvanized after fabrication for a truly rust free and abrasive resistant finish that is unmatched in the industry. Commercial Van Toppers.

Available in 10, 12, and 14 foot lengths, each van rack can carry up to 750 pounds with rubber spacers that separate the mounting system hardware from the finished surfaces of your van. Optional conduit carriers carry your conduit neatly and safely with any van rack.



SLICK Locks



- ✓ Easy installation
- ✓ NO holes are drilled into vehicle
- ✓ NO damage and corrosion to exterior
- ✓ NO more traditional bolt through hasp design

THUNDERBOLT - Electric Anti-Theft Locks



This two-door work van kit secures the van's cargo area doors and is operated by the van's factory key fob. The included raised strike bracket (if needed) gets surfaced-mounted on the rear driver-side door, allowing the lock to be installed in the rear passenger-side door. The second lock gets installed inside the side door.

Note: Some Models Work with Factory Keyfobs

M1
Two-Door Kit

Other styles and model available

TOMMY GATE - Internal Van Lifts



The Internal Van Lift

Low-capacity, compact, and internally-mounted, the 650 Series is the ideal liftgate for lightweight van applications. 650 Series models fold up and store out of the way of ordinary tasks or flat against the inside of the rear door. Fold-away interior mount offers two secure storage positions and easy access to the rear of the van.

LIFTGATE CAPACITY

650 lbs.

HYDRAULIC SYSTEM

Single-Cylinder

VAN LIFT LOCATION

Internally-Mounted

650 Series Features

Fold-away interior mount offers two secure storage positions and easy access to the rear of the van.

Other styles and model available



LINK Manufacturing - Aluminum Van Ramps

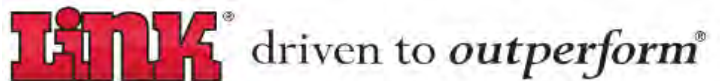

Spring-Assisted Loading Ramp

Link Manufacturing has developed a broad array of deployable mounted loading aluminum ramp solutions engineered for commercial vans and box trucks. Link's lightweight, low-profile, aluminum LB20 ramps ship fully assembled and mount just inside a vehicle's rear or side door. Each LB20 mounted ramp is made from high-strength aluminum and engineered for ease of use and installation.



PERFECT FOR QUICK LOADING & UNLOADING

The LB20 is easy to deploy with quick-release latches and sturdy hinge points. The mounted ramp works perfectly for vans or medium-duty vehicles for rear or side door loading applications.

LOW-PROFILE THRESHOLD

The top of the ramp features a low-profile transition threshold to provide a shallow approach for various types of equipment. The unique lifting mechanism also allows for necessary bumper clearance.

HIGH STRENGTH ALUMINUM

The LB20 ramp is made of extruded high-strength aluminum and is designed for reliability and durability. The extensive line of LB20 sizes provides an option for any delivery application.

SHIP FULLY ASSEMBLED

All LB20 ramps ship fully assembled, include a wheel kit, and mount just inside a vehicle's rear or side door.

The diverse LB20 ramps are fast, easy, and convenient to deploy, use, and stow. The ramp can be unfolded and folded back into a vertical, low-profile storage position in less than a couple of seconds. By stowing vertically inside the vehicle's cargo hold, the ramp is not exposed to the weather or road debris and takes up less than 11 inches of horizontal

Other styles and models available

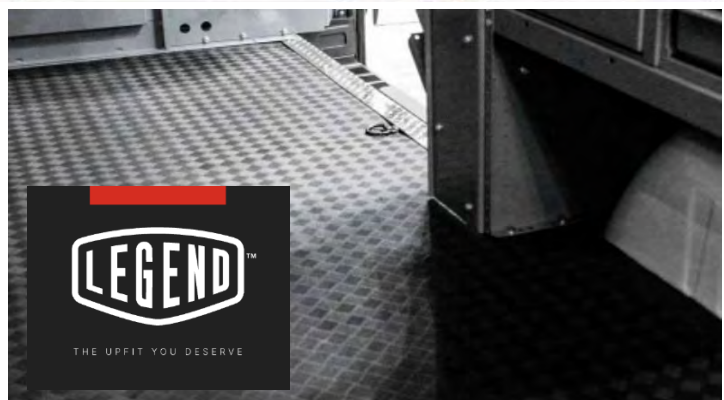
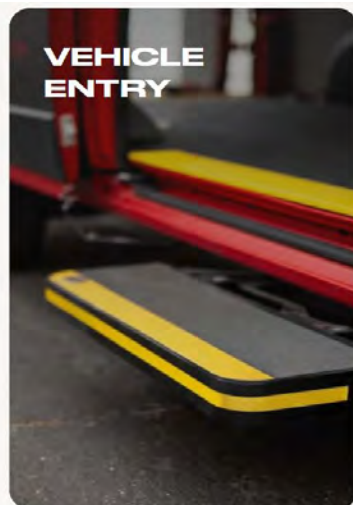

Motion Sensor LED
Ceiling Lights
Keep it Bright, Even at Night
Available in sets of 2, 3 or 4

Complete your Upfit with these accessories



Webasto
Heaters



Power
Invertors



Safety
& Task
Lighting



Trailer
Hitch



Cruise Controls
&
Trailer Wiring

COLORADO

Commerce City
303-630-1030



ILLINOIS

Villa Park
630-530-7580



MARYLAND

Elkridge
301-490-0281



MINNESOTA

Spring Lake Park
763-784-4111



NEW JERSEY

South Hackensack
201-438-5400



OHIO

Hamilton
513-860-9720



WISCONSIN

Brookfield
262-232-8891



CERTIFIED
INSTALLER

